

On these pages you will convert one metric unit to another and solve problems using metric units.

**length**

10 mm = 1 cm  
100 cm = 1 m  
1000 m = 1 km

**mass**

1000 g = 1 kg  
1000 kg = 1 tonne  
(1t)

**capacity**

1000 ml = 1 litre

**Examples**

2000 m = 2 km  
2500 m = 2.5 km

0.87 m = 87 cm  
2719 g = 2.719 kg

1.8 l = 1800 ml  
2250 g = 2.25 kg

**M**

Write down which metric unit you would use to measure the following:

- 1 The length of an ant.
- 2 The amount of water in a swimming pool.
- 3 The distance from London to Paris.
- 4 The capacity of a car's petrol tank.
- 5 The mass of a lorry.
- 6 Write each length in cm.  
a) 3 m                      b) 1.8 m                      c) 20 mm                      d) 0.4 m
- 7 Write each length in km.  
a) 5000 m                      b) 2300 m                      c) 650 m                      d) 100 000 m
- 8 Write each mass in g.  
a) 2 kg                      b) 1.65 kg                      c) 0.7 kg                      d) 0.085 kg
- 9 Write each mass in kg.  
a) 2 tonnes                      b) 50 tonnes                      c) 5500 g                      d) 600 g

Copy and complete.

- |                                    |                                    |  |                                     |
|------------------------------------|------------------------------------|--|-------------------------------------|
| 10 3 m = <input type="text"/> cm   | 15 8 cm = <input type="text"/> mm  | 20 800 g = <input type="text"/> kg     | 25 2.5 m = <input type="text"/> cm  |
| 11 1.5 km = <input type="text"/> m | 16 60 cm = <input type="text"/> m  | 21 8 tonnes = <input type="text"/> kg  | 26 8.7 m = <input type="text"/> cm  |
| 12 7 kg = <input type="text"/> g   | 17 2 m = <input type="text"/> cm   | 22 2.6 kg = <input type="text"/> g     | 27 58 mm = <input type="text"/> cm  |
| 13 500 g = <input type="text"/> kg | 18 0.6 m = <input type="text"/> cm | 23 3 litres = <input type="text"/> ml  | 28 0.45 kg = <input type="text"/> g |
| 14 30 mm = <input type="text"/> cm | 19 1.2 kg = <input type="text"/> g | 24 32 litres = <input type="text"/> ml | 29 8 g = <input type="text"/> kg    |

**E**

- 1** George swims 4 km every day. The pool is 50 m in length. How many lengths does he swim in one week?



- 2** Seema cut 68 cm from 2 m of string. She then cut a further 35 cm. How much string is left?
- 3** A rectangular field is 1586 m long and 234 m wide. How long is the fence around it in kilometres?
- 4** A car travels 25 m every second. How far does it travel in kilometres in five minutes?
- 5** A carpenter needs sixteen 40 cm lengths of wood. How many metres of wood does he need to order?
- 6** In June a plant grew 1.5 metres. On average how much did it grow each day? Give your answer in millimetres. [30 days in June.]
- 7** 150 Oxo cubes weigh 0.9 kg. What does one Oxo cube weigh in grams?
- 8** Mrs. Gregg receives two parcels. One weighs 380 g. The other is twice as heavy.

What is their combined weight in kilograms?

- 9** A loaf of bread weighs one kilogram. It contains 25 slices.

What does each slice weigh in grams?

- 10** A shelf has 46 paperback books, each weighing 200 g.

How much weight is the shelf supporting in kilograms?

- 11** 4 identical containers are loaded onto a lorry. Their combined weight is 2.74 t. What is the weight of each container in kilograms?

- 12** A ship has 4.2 tonnes of cargo in the hold. 1368 kg is removed. How much cargo is left?



- 13** Eight 350 ml beakers are filled from a full 4.5 litre flask of tea. How much tea in ml is left in the flask?
- 14** How many 200 ml cartons of milk can be filled from a 10 litre churn?
- 15** There are 12 bottles of wine in a box. Each bottle contains 70 cl. How much wine is there altogether in litres?
- 16** A petrol pump delivers 400 ml of petrol every second. How many litres of petrol will it deliver in one minute?

Max is 14 next month. He wants to have a party in a local hall. The hire cost of the hall is shown below.

Sunday to Thursday	£6 for every 10 people
Friday/Saturday	£12 for every 22 people

The party will start with food. People can sit around a table as shown below.



The tables are laid out in the hall as shown below.

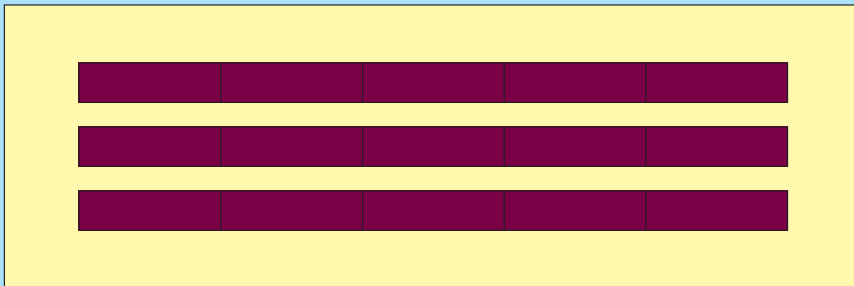

Everyone at the party must be able to sit down for the food.

### Part A

- 1 If every seat is used, how many people can come to the party?
- 2 If all these people come to the party on a Friday night, how much will Max have to pay to hire the hall?

For this party Max needs to buy the food listed below:

22 pizzas	15 packets of cherry tomatoes
15 dips	11 packets of crisps
11 packets of bread sticks	100 chocolate brownies
5 kg grapes	66 cupcakes
16 packets of sausages	15 bottles of cola
10 packets of salad leaves	15 bottles of lemonade



The prices of food in 3 supermarkets is shown below:

Sureway	
pizza	£2.99
dip	£1.40
breadsticks	99p per packet
grapes	£3.25 per kg
sausages	£1.85 per packet
salad leaves	£1.75 per packet
cherry tomatoes	£1.65 per packet
crisps	£1.49 per packet
chocolate brownies (packet of 10)	£2.10 per packet
cupcakes (packet of 6)	£1.25 per packet
cola	£1.50 per bottle
lemonade	£1.40 per bottle

Fairbuy	
grapes	£2.95 per kg
cherry tomatoes	£1.70 per packet
crisps	£1.35 per packet
cola	£1.35 per bottle
sausages	£2.15 per packet
breadsticks	£1.10 per packet
lemonade	£1.15 per bottle
dip	£1.25
cupcakes (packet of 6)	99p per packet
pizza	£2.49
salad leaves	£1.65 per packet
chocolate brownies (packet of 10)	£2 per packet

Soundtrade	
lemonade	£1.20 per bottle
salad leaves	£1.95 per packet
breadsticks	£1.05 per packet
dip	£1.15
chocolate brownies (packet of 10)	£1.85 per packet
cola	£1.55 per bottle
pizza	£2.35
crisps	£1.25 per packet
sausages	£1.95 per packet
cherry tomatoes	£1.60 per packet
grapes	£3 per kg
cupcakes (packet of 6)	£1.40 per packet

### Part B

Max only has time to shop for all the food in one supermarket. Which shop will be the cheapest and how much will Max spend if he shops in this supermarket?

When the tables have been put away, Max needs music. To decide on the best music, he asks 50 friends what their favourite music is. Their answers are recorded below:

D = dance

M = metal

R = R & B

H = Hip Hop

P = pop

M	D	H	M	D	R	H	M	P	H
H	D	M	D	M	P	D	D	P	M
R	M	H	D	R	H	D	M	H	D
D	D	M	H	M	H	P	R	M	D
M	H	D	H	D	M	H	H	D	P

### Part C

Max thinks that the most popular music is 'Dance'. Is Max correct?

Show *exactly* why you think this is the answer.



Max knows 3 people who can offer the music. Max wants music for 4 hours. The cost of each person is shown below.

Dan's Rave
£25 plus £2.50 for every 6 people at the party

Kilo's Beam
£35 plus £6 per hour

Jedgroove
£72 for the whole party

### Part D

- 1 Who is the cheapest? (remember to look at your answer to part A)
- 2 Who is the most expensive?
- 3 What is the difference in the cost of the cheapest and the most expensive?

### Part E

Max wants to make a big poster with his name.

He enlarges each letter above by a scale factor 2.

What is the *new* total area of the 3 letters if each small square is  $4\text{cm}^2$ ?



#### Sam's Cab

£4 plus  
80p per km

#### Roy's Cars

£3 plus  
£1 per km

#### Kate's taxis

£3.50 plus  
90p per km

Tina, Marvin and Rory live close to each other on the same street. After the party they each take a different taxi to get home. Each journey is 8km and the cost of each taxi is shown below.

Tina takes Sam's Cab.  
It leaves the hall at 10:53 p.m. and gets Tina home in 48 minutes.

Marvin takes Roy's Cars.  
It leaves the hall at 11:04 p.m. and gets Marvin home in 36 minutes.

Rory takes Kate's taxis.  
It leaves the hall at 10:58 p.m. and gets Rory home in 45 minutes.

### Part F

Who gets home first and who pays the least money for the taxi? Your *must* show all your working out.

On these pages you will find the areas of triangles and rectangles.

### Reminder Rectangle

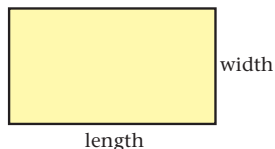

$$\text{Area} = \text{length} \times \text{width}$$

$$A = lw$$

### Triangle

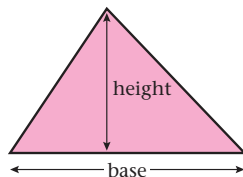

$$\text{Area} = (\text{base} \times \text{height}) \div 2$$

This can be written as

$$\text{Area} = \frac{1}{2} (\text{base} \times \text{height})$$

$$A = \frac{1}{2} bh$$

### Examples

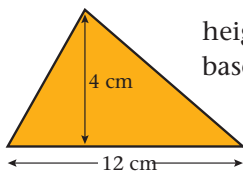

height = 4 cm  
base = 12 cm

$$\begin{aligned} \text{Area of triangle} &= \frac{1}{2}bh \\ &= \frac{1}{2} \times 12 \times 4 \\ &= 6 \times 4 = 24 \text{ cm}^2 \end{aligned}$$

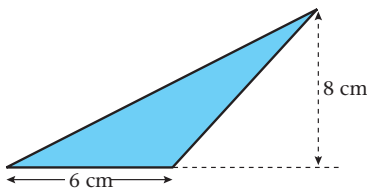

height = 8 cm  
base = 6 cm

$$\begin{aligned} \text{Area} &= \frac{1}{2}bh \\ &= \frac{1}{2} \times 6 \times 8 \\ &= 3 \times 8 = 24 \text{ cm}^2 \end{aligned}$$

## M

In Questions 1 to 12, find the area of each shape.

All lengths are in cm.

1



3

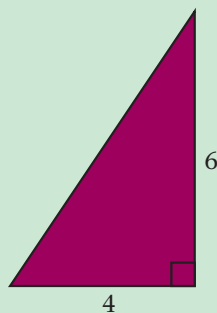

2

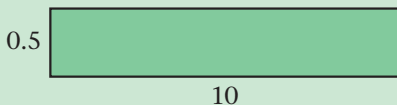

4

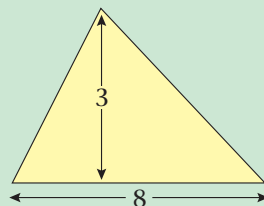

5

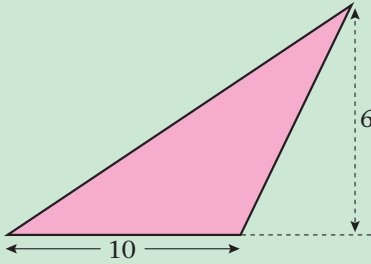

9

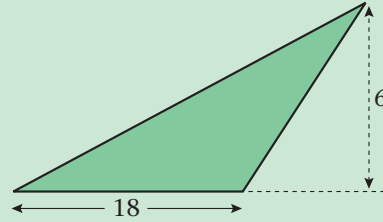

6

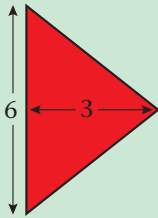

10

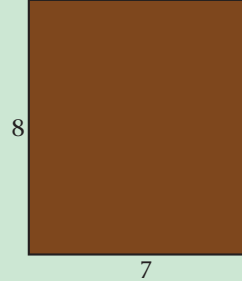

7

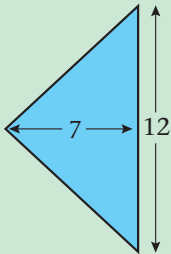

11

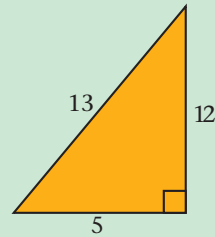

8

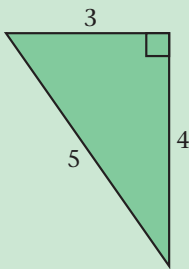

12

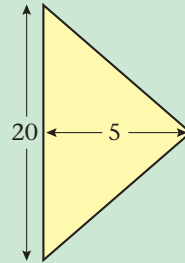

**13** Find the area of a triangle with a base of 14 cm and a height of 6 cm.

**14** Find the area of a triangle with a base of 20 cm and a height of 11 cm.

**15** A rectangle has an area of  $80 \text{ cm}^2$ . The width of the rectangle is 4 cm. What is the length of the rectangle?

**16** A triangle has an area of  $40 \text{ cm}^2$ . The base of the triangle is 16 cm. What is the height of the triangle?

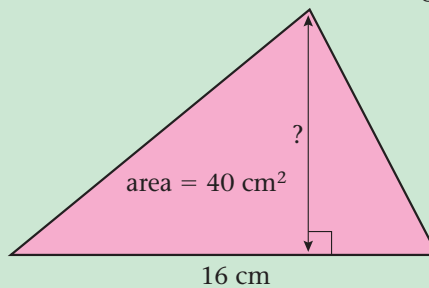

## E

- 1 Match one area and one perimeter to each shape. There will be one area and one perimeter left over.

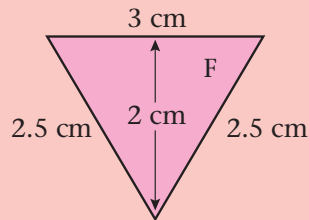
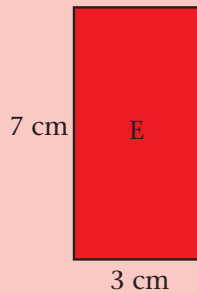
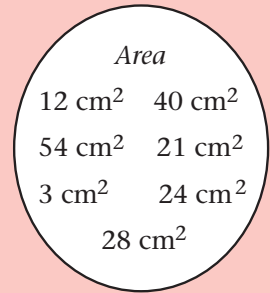
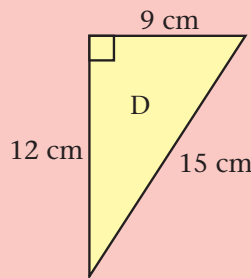
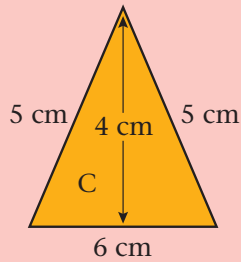
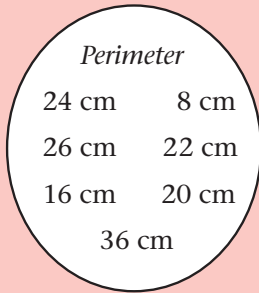
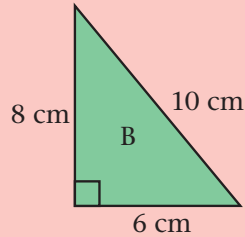
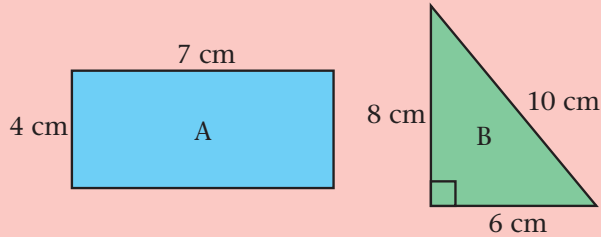

- 2 Write down the area and perimeter which are left over from question 1. Draw a shape which has this area *and* this perimeter.

- 3 The height of this picture is 8 cm more than the length. The perimeter of the picture is 100 cm. Work out the length of the picture.



On these pages you will find areas of shapes made from rectangles and triangles.

Many shapes are made from rectangles and triangles.

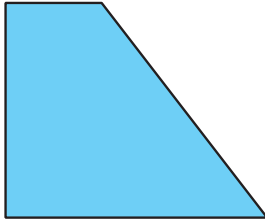

Can be cut into a rectangle and a triangle.

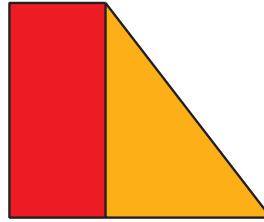

To find the area of the large shape, find the area of the rectangle and the area of the triangle then add them together.

### Example

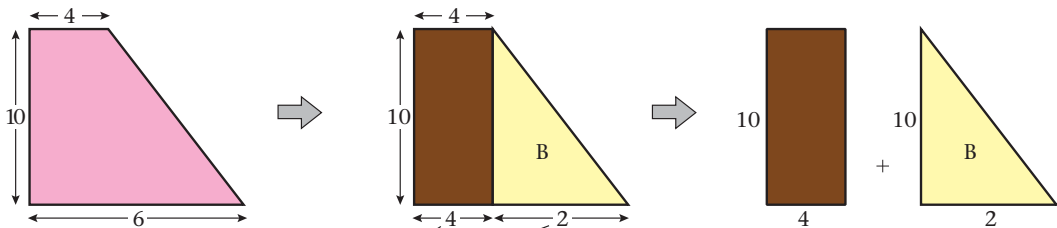

6 must equal  $4 + 2$  along the bottom side

Area rectangle A =  $10 \times 4 = 40$

Area triangle B =  $\frac{1}{2} \times 2 \times 10 = 10$

Total area =  $40 + 10 = 50$

If each length is given in cm, the area of the shape is  $50 \text{ cm}^2$ .

## M

Use triangles and rectangles to find the area of each shape in Questions 1 to 12. All lengths are in cm.

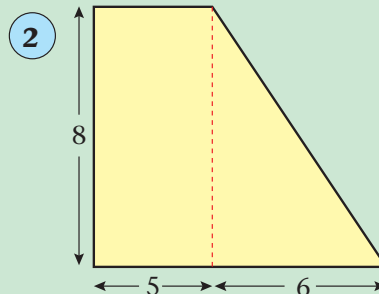
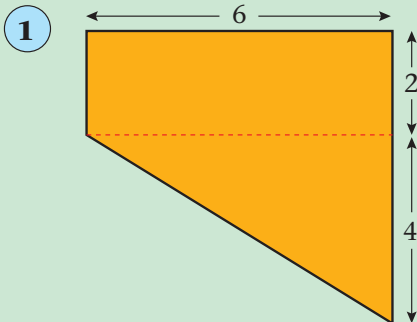

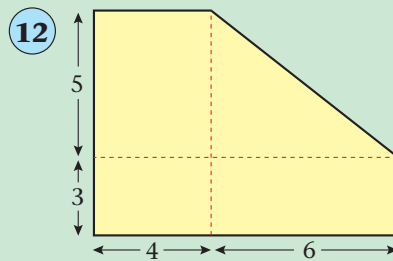
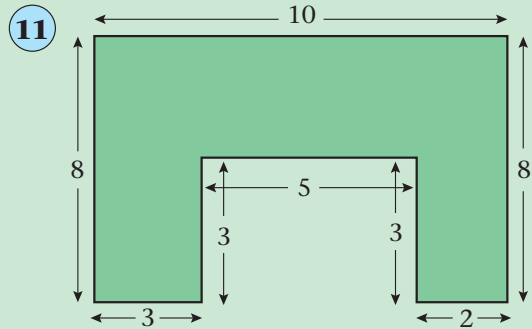
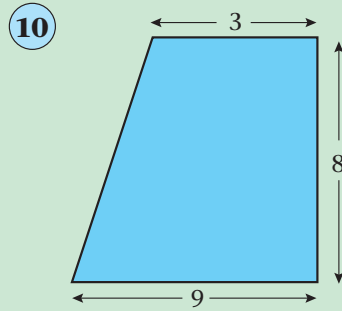
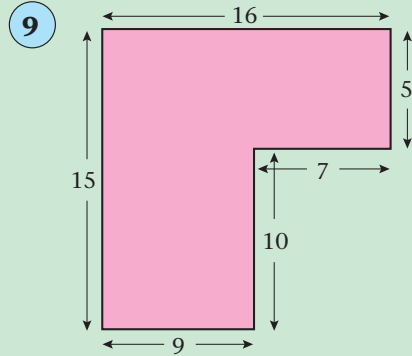
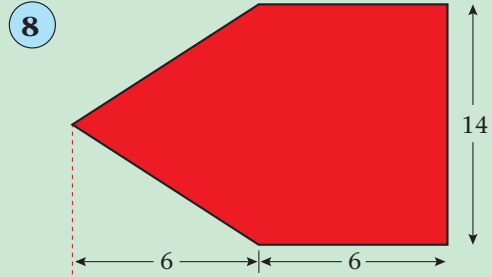
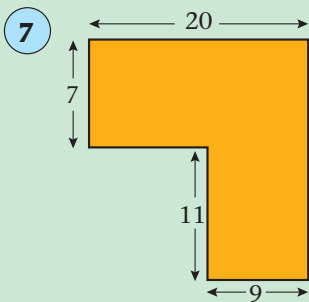
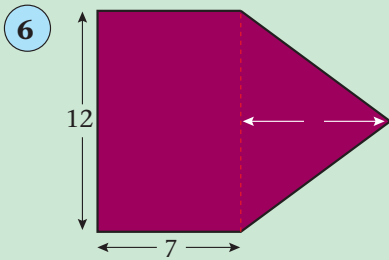
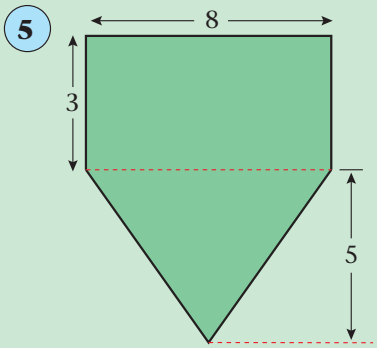
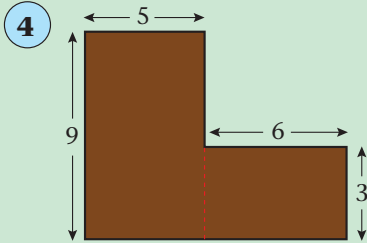
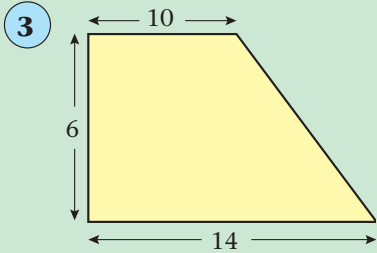

In each of Questions **13** to **16**, find the shaded area.

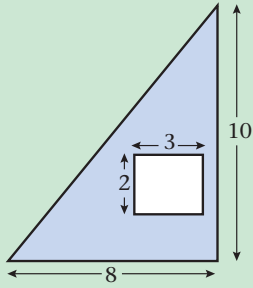
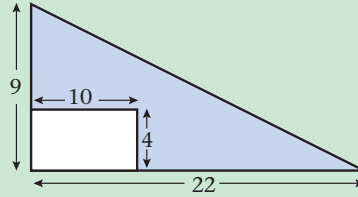
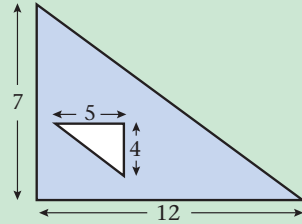
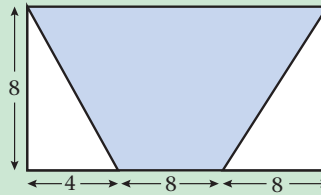
**13****15****14****16****E**

You may use a *calculator* for these Questions.

Find the area of each shape in Questions **1** to **4**.

All the lengths are in cm.

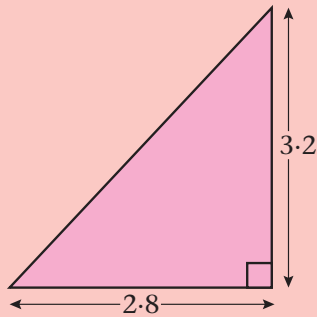
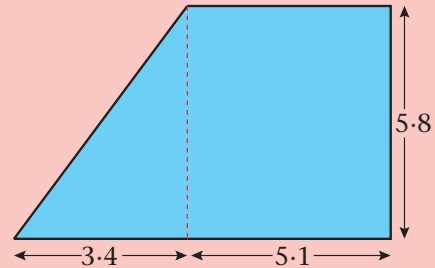
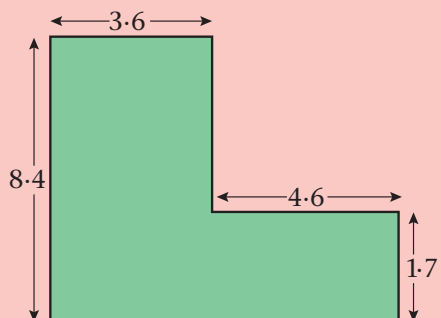
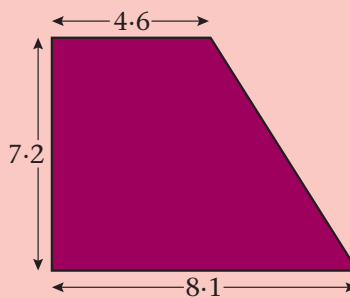
**1****3****2****4**

- 5 Find the area of the end of this shed.

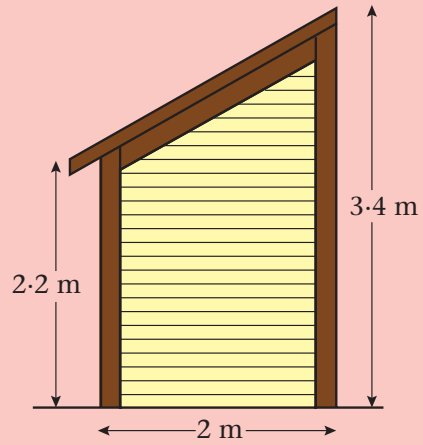

- 6 Find the area of each of the lawns shown below:

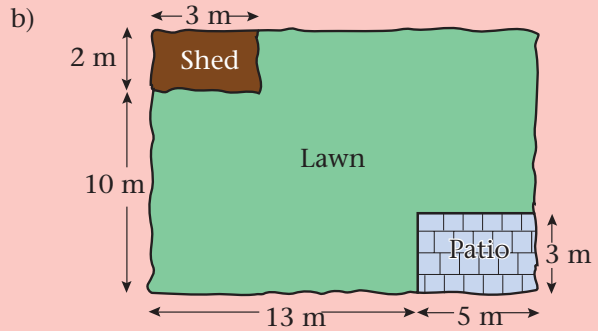
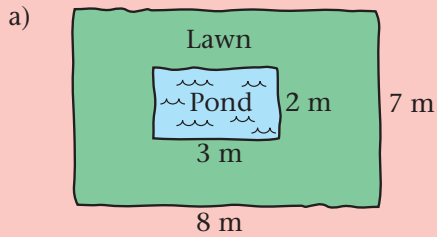

- 7 Find the total shaded area in this shape. All the lengths are in cm.

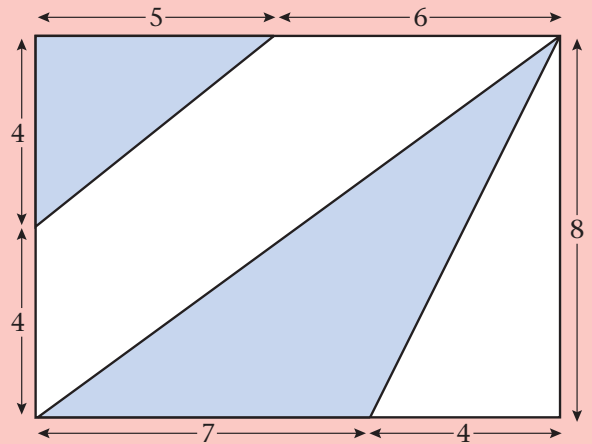

- 8 The area is written inside the triangle. Calculate  $x$ .

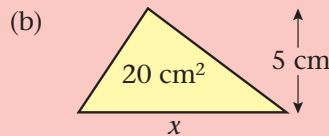
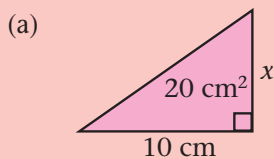

On these pages you will find the surface area and volume of different cuboids.

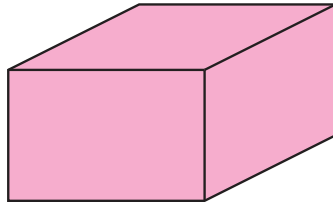

Cuboid

*Surface area*

To find the total surface area of a cuboid, you must find the *area of each face* (front, back, top, bottom and two sides) and *add* these areas together.

Volume = length  $\times$  width  $\times$  height

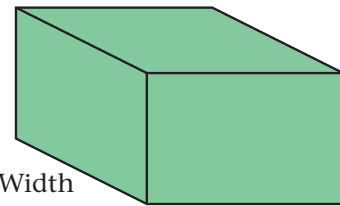

Height

Width

Length

**M**

**1** Find the surface area of the top face of each cuboid:

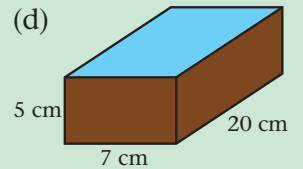
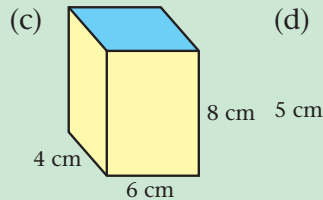
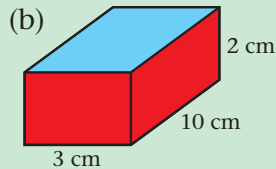
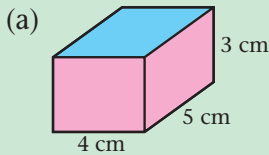

**2** Find the surface area of the back face of each cuboid:

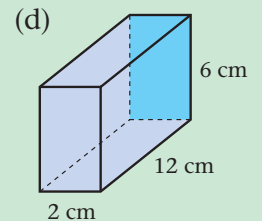
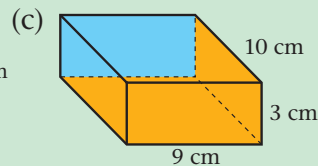
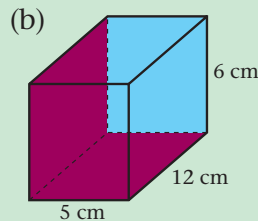
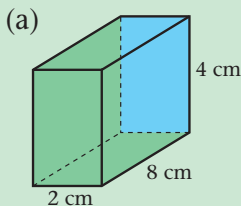

3 Copy and complete the tables below to find the *total surface area* of each cuboid.

a)

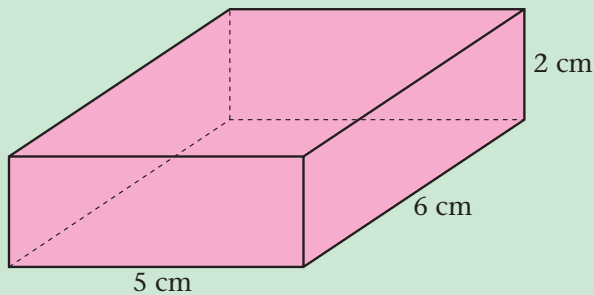

Face	Area (cm <sup>2</sup> )
Front	10
Back	
Top	
Bottom	
Side 1	
Side 2	12
Total =	

b)

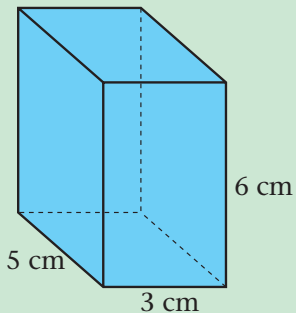

Face	Area (cm <sup>2</sup> )
Front	
Back	
Top	
Bottom	
Side 1	
Side 2	
Total =	

4 Find the *total surface area* of each cuboid below:

a)

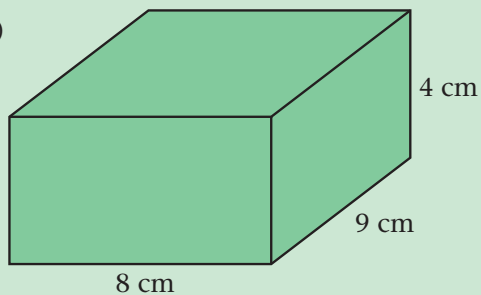

b)

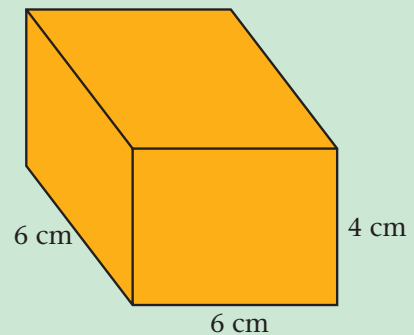

5 Each cuboid below is an open box (this means there is no top face). For each cuboid, find the total surface area of the outside faces.

a)

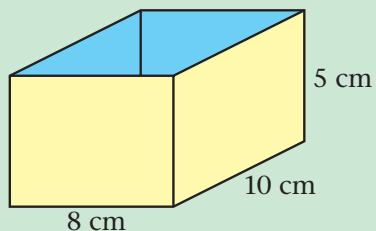

b)

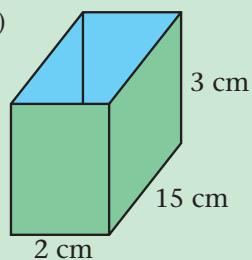

c)

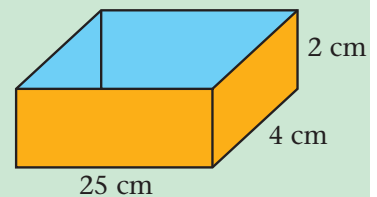

**E**

Find the volume of each cuboid below:

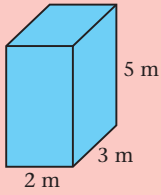
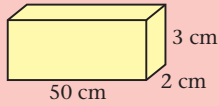
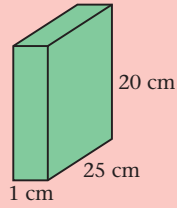
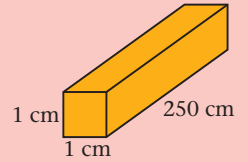
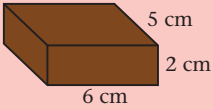
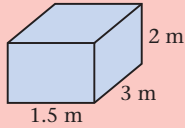
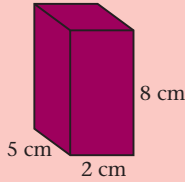
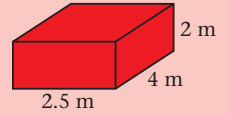
**1****3****5****7****2****4****6****8**

Find the total surface area *and* the volume of each cuboid below:

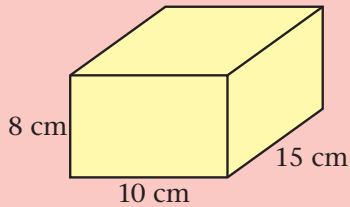
**9**

a pat of butter  $10\text{ cm} \times 15\text{ cm} \times 8\text{ cm}$

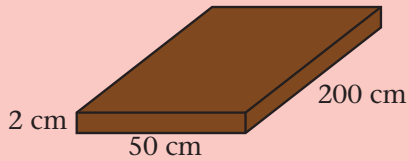
**10**

a plank of wood  $50\text{ cm} \times 200\text{ cm} \times 2\text{ cm}$

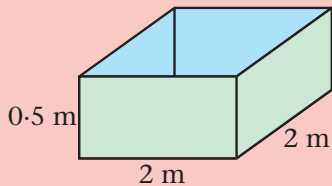
**11**

a paddling pool (no top face)  $2\text{ m} \times 2\text{ m} \times 0.5\text{ m}$

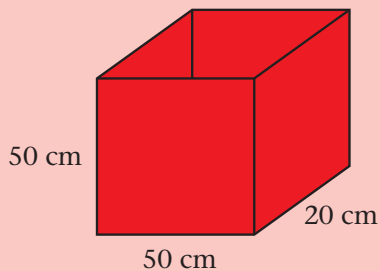
**12**

an open box  $50\text{ cm} \times 50\text{ cm} \times 20\text{ cm}$

On these pages you will read the time from different clocks using 12-hour clock time and 24-hour clock time. You will also use timetables.

a.m. means ante meridiem.  
It is used for times before noon.  
p.m. means post meridiem.  
It is used for times after noon.

24-hour clocks always have four digits on display,  
A 24-hour clock displays midnight as 00:00

**Examples**

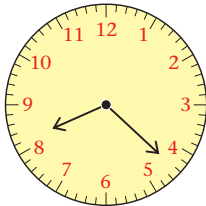

Morning

22 minutes past 8  
8:22 a.m. 12-hour clock  
08:22 24-hour clock

12 minutes to 7  
6:48 p.m.  
18:48

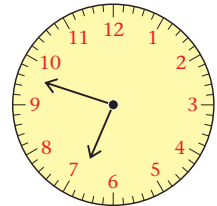

Evening

**M**

Write each time shown to the nearest minute:

a) in words

b) in 12-hour clock time using a.m. and p.m..

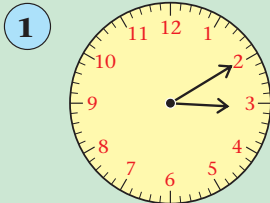

Afternoon

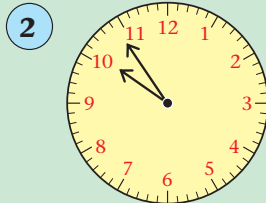

Morning

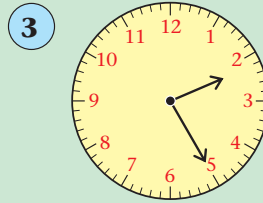

Night

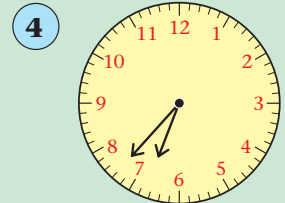

Evening



Lunchtime



Night



Evening



Morning

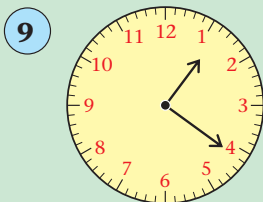

Afternoon

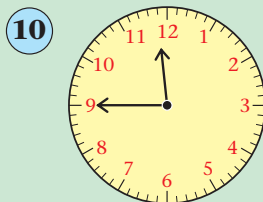

Night

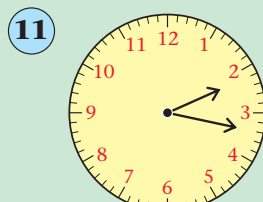

Morning

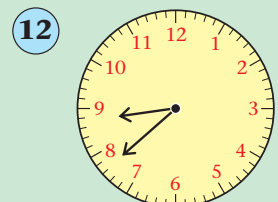

Breakfast

13 Write the 12-hour clock times if each of the twelve clocks above was:

a) 9 minutes slow

b) 6 minutes fast.

- 14** Copy and complete the table.

TIME IN WORDS	12-HOUR CLOCK	24-HOUR CLOCK
three o' clock	3:00 p.m.	15:00
		07:45
		20:30
		10:35
		03:52
	10:19 p.m.	
	9:37 a.m.	
	6:16 p.m.	
	11:28 a.m.	
	5:53 p.m.	

- 15** For each of the times in Question **14**, work out how many minutes there are to the next hour.

- 16** Look at the calendar.  
Is this a leap year? How do you know?

FEBRUARY						
Su	M	Tu	W	Th	F	Sa
	1	2	3	4	5	6
7	8	9	10	11	12	13
14	15	16	17	18	19	20
21	22	23	24	25	26	27
28						

- 17** On what day will these children have their birthday?

- Gavin — 4th February
- Kate — 23rd February
- Davina — 6th March
- Amanda — 31st January

- 18** Christmas Day is a Tuesday.  
What day of the week is New Year's Eve?



- 19** A school begins its half term holiday on Friday 23rd October. The holiday lasts one week. What is the date of the first Monday back at school?

- 20** It is June 15th. Levi's birthday is in three weeks time. What is the date of his birthday?

**E**

Use this train timetable for the questions below:

Waterloo (London)	07:10	08:35	11:35	13:50
Woking	07:35	–	12:00	14:15
Basingstoke	07:55	09:21	12:21	–
Andover	08:16	–	12:42	–
Salisbury	08:36	09:54	13:17	15:08
Yeovil	09:24	10:42	14:07	15:48
Honiton	10:01	–	14:53	16:34
Exeter	10:27	11:42	15:18	16:59

- 1 How long does it take the 07:10 from Waterloo to travel to:
    - a) Woking
    - b) Basingstoke
    - c) Andover?
  - 2 At how many stations does the 11:35 from Waterloo stop?
  - 3 At what time does the 08:35 from Waterloo reach Salisbury?
  - 4 If you had to be in Exeter by 15:30 which train would you catch from Waterloo?
  - 5 You arrive at Waterloo at 08:20. How long do you have to wait for the next train to Exeter?
  - 6 The 11:35 from Waterloo runs 10 minutes late. At what time will it reach Andover?
- 
- 7 How long does it take the 11:35 from Waterloo to travel to:
    - a) Salisbury
    - b) Yeovil
    - c) Exeter?
  - 8 At how many stations does the 08:16 from Andover stop before it reaches Honiton?
  - 9 At what time does the 12:21 from Basingstoke reach Yeovil?
  - 10 If you had to be in Exeter by 12:00 which train would you catch from Basingstoke?
  - 11 You arrive at Waterloo at 11:08. How long do you have to wait for the next train to Exeter?
  - 12 The 08:35 from Waterloo runs 19 minutes late. At what time will it reach Exeter?
  - 13 How long does it take the 07:55 from Basingstoke to travel to:
    - a) Salisbury
    - b) Yeovil
    - c) Exeter?
  - 14 At how many stations does the 09:21 from Basingstoke stop before it reaches Exeter?
  - 15 At what time does the 14:15 from Woking reach Honiton?
  - 16 If you had to be in Honiton by 16:00 which train would you catch from Salisbury?
  - 17 You arrive at Waterloo at 10:42. How long do you have to wait for the next train to Exeter?
  - 18 The 11:35 from Waterloo runs 38 minutes late. At what time will it reach Honiton?

On these pages you will round off numbers and work out rough answers for different problems.

- Using a calculator,  $\sqrt{11} = 3.3166248$

We can *round off* this number to either 1 or 2 decimal places.

- Rounding to one decimal place.

If the figure in the 2nd decimal place is *5 or more*, round up.

Otherwise do not.

$$2.761 = 2.8 \text{ to 1 d.p.}$$

↑

$$13.45 = 13.5 \text{ to 1 d.p.}$$

↑

$$0.337 = 0.3 \text{ to 1 d.p.}$$

↑

- Rounding to two decimal places.

If the figure in the 3rd decimal place is *5 or more*, round up.

Otherwise do not.

$$1.4281 = 1.43 \text{ to 2 d.p.}$$

↑

$$0.0742 = 0.07 \text{ to 2 d.p.}$$

↑

$$8.555 = 8.56 \text{ to 2 d.p.}$$

↑

## M Part One

- 1 Round off these numbers correct to one decimal place.

- |          |          |          |           |
|----------|----------|----------|-----------|
| a) 8.24  | c) 0.762 | e) 0.352 | g) 11.518 |
| b) 7.166 | d) 11.27 | f) 8.741 | h) 0.648  |

- 2 Round off these numbers correct to two decimal places.

- |          |           |           |           |
|----------|-----------|-----------|-----------|
| a) 1.246 | c) 11.222 | e) 0.1355 | g) 0.8592 |
| b) 8.043 | d) 3.084  | f) 22.456 | h) 6.097  |

- 3 Work out these answers on a calculator and then round off the answers correct to two decimal places.

- |                      |                        |                       |                              |
|----------------------|------------------------|-----------------------|------------------------------|
| a) $11.21 \div 7$    | d) $12.6 \times 0.071$ | g) $1.36^2$           | j) $11.82 \div 13$           |
| b) $0.54 \times 8.1$ | e) $\sqrt{13}$         | h) $0.97^2$           | k) $2.4 \times 0.716$        |
| c) $4216 \div 214$   | f) $\sqrt{8.5}$        | i) $0.77 \times 0.78$ | l) $\sqrt{(4.2 \times 3.5)}$ |

- 4 Round off these numbers to the nearest hundred.

- |           |           |          |         |
|-----------|-----------|----------|---------|
| a) 1741   | c) 807.1  | e) 562.8 | g) 3552 |
| b) 22 483 | d) 15 255 | f) 2222  | h) 1027 |

## M Part Two

1 Estimate the lengths shown. Use the ruler as a guide

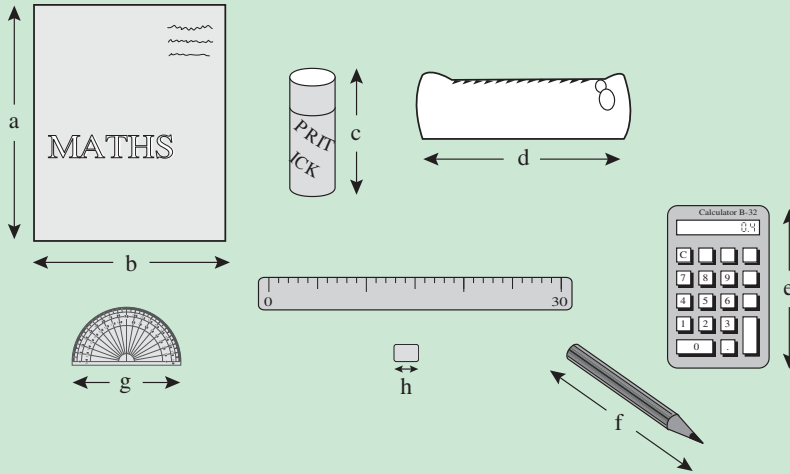

2 Look at the picture. The person is about 2 metres tall.



Estimate the height of:

- The top of the roof of the house
- The ladder
- The tree
- The telegraph pole
- The nest box on the tree.

3 Estimate the reading on each thermometer.



- Harry worked out  $506.3 \div 9.5$  and wrote down 5.3295. He can check his answer by working with estimates. Instead of 506.3 use 500, instead of 9.5 use 10.

$$\text{So } 500 \div 10 = 50.$$

Clearly Harry's answer is wrong. He put the decimal point in the wrong place.

- Here are three more calculations with estimates.

a)  $31.2 \times 9.2$

$$\approx 30 \times 10$$

$$\approx 300$$

b)  $28.4 \div 0.971$

$$\approx 30 \div 1$$

$$\approx 30$$

c) 11% of £78.99

$$\approx \frac{1}{10} \text{ of } \text{£}80$$

$$\approx \text{£}8$$

## E

*Do not use a calculator.*

From the table below, choose the most sensible ROUGH answer from A, B or C.

	Calculation	A	B	C
1	$6.73 \times 9.65$	30	70	300
2	$2.3 \times 96$	200	90	20
3	$1.02 \times 60.7$	6	60	200
4	$5.14 \times 5.99$	15	10	30
5	$18.8 \times 20.7$	200	400	4000
6	$807 \times 11.31$	8000	4000	800
7	$1.09 \times 29.6$	20	30	60
8	$402 \div 4.97$	8	0.8	80
9	$601 \div 3.92$	50	100	150
10	$58.4 \div 0.98$	60	300	600
11	$217 \div 201.4$	0.2	1	10
12	$99 \times 98$	1 million	100000	10000
13	$88.4 + 95 + 141$	300	100	3000
14	$0.32 + 0.294$	0.06	0.1	0.6
15	11% of £198.20	£10	£20	£200

Do not use a calculator in Questions **16** to **20**.

**16** A cut-price DVD was sold at £6.95 per copy. *Estimate* the total cost of 42 copies.

**17** A do-it-yourself table and chairs kit cost £38.49.  
*Estimate* the total cost of 11 kits.



**18** The rent for a flat is £95 per week. *Estimate* the total spent on rent in one year (52 weeks in 1 year).

**19** A calculator costs £5.99. *Estimate* the total cost of 31 calculators.

**20** 38 people pay a total of £1247 for a holiday trip. *Roughly how much* does each person pay?

### Estimating game

- This is a game for two players. On squared paper draw an answer grid with the numbers shown.

Answer grid

198	1089	99	100	360	18
180	450	22	440	155	1980
1240	200	45	62	100	550
40	620	495	279	800	55
2000	80	220	10	891	250
4950	1550	1000	3960	3069	341

Question grid

2	5	9
11	20	31
40	50	99

The number obtained is crossed out on the answer grid using the player's own colour.

- The game continues until all the numbers in the answer grid have been crossed out. The object is to get four answers in a line (horizontally, vertically or diagonally). The winner is the player with most lines of four.
  - A line of *five* counts as *two* lines of four. A line of *six* counts as *three* lines of four.
- The players now take turns to choose two numbers from the question grid below and multiply them on a calculator.

On this page you will practise adding and subtracting.

## Remember

To add or subtract decimals, line up the decimal point.

## M

Work out (write out in columns first if you need to)

- |  |                        |                     |
|--|------------------------|---------------------|
| <b>1</b> a) $17 + 23 + 56$             | f) $145 - 96$          | k) $19.6 + 3.2$     |
| b) $35 + 27 + 18$                      | g) $221 - 108$         | l) $49.81 + 16.1$   |
| c) $16 + 39 + 17$                      | h) $956 - 783$         | m) $16.02 + 7.5$    |
| d) $106 + 32 + 19$                     | i) $902 - 583$         | n) $0.73 + 12.9$    |
| e) $159 + 216 + 17$                    | j) $763 - 198$         | o) $3.77 + 21.08$   |
| <b>2</b> a) $1937 + 213$               | f) $8193 - 218$        | k) $368.2 - 195$    |
| b) $6541 + 2179$                       | g) $16527 - 4831$      | l) $804 - 55.6$     |
| c) $1002 + 7466$                       | h) $17763 - 816$       | m) $39.45 - 17.1$   |
| d) $2983 + 6659$                       | i) $25314 - 9368$      | n) $216.3 - 87.42$  |
| e) $3941 + 7988$                       | j) $41835 - 9217$      | o) $531.2 - 104.56$ |
| <b>3</b> a) $£29.46 + £35.81 + £16.23$ | f) $£19.08 - £6.43$    |                     |
| b) $£103.90 + £78.57 + £19.02$         | g) $£306.41 - £182.77$ |                     |
| c) $£50.08 + £27.56 + £41.75$          | h) $£93.02 - £57.64$   |                     |
| d) $£38.57 + £19.92 + £28.07$          | i) $£100 - £58.36$     |                     |
| e) $£251.26 + £83.04 + £166.49$        | j) $£253.71 - £189.94$ |                     |

## E

- Each member of a  $4 \times 100$  m relay team ran their 100 m leg in 11.03, 10.95, 11.1 and 10.64. What was their total time?
- For 'Children in Need' Sachin, Paul and Leena raised £105.72, £98.46 and £138.10. How much did they raise altogether?
- In a greyhound race the times for the first two dogs were 43.9 seconds and 44.06 seconds. How many seconds was the first dog quicker by?
- The lengths of three worms were 10.53 cm, 9.6 cm and 8.69 cm. What was the total length of the three worms?

## M

Work out:

①  $33 \times 25$

⑥  $123 \times 32$

⑪  $714 \div 17$

⑯  $864 \div 36$

②  $17 \times 13$

⑦  $245 \times 18$

⑫  $294 \div 14$

⑰  $609 \div 29$

③  $29 \times 14$

⑧  $306 \times 43$

⑬  $756 \div 12$

⑱  $612 \div 36$

④  $38 \times 56$

⑨  $517 \times 19$

⑭  $768 \div 32$

⑲  $990 \div 22$

⑤  $19 \times 37$

⑩  $225 \times 81$

⑮  $864 \div 16$

⑳  $361 \div 19$

## E Part One

①  $6 \times 0.3$

⑥  $0.3 \times 0.2$

⑪  $0.01 \times 18$

⑯  $15.2 \times 0.2$

②  $8 \times 0.2$

⑦  $0.5 \times 0.1$

⑫  $22 \times 0.03$

⑰  $4.03 \times 0.4$

③  $7 \times 0.4$

⑧  $7 \times 0.22$

⑬  $0.31 \times 8$

⑱  $20.7 \times 0.4$

④  $12 \times 0.3$

⑨  $15 \times 0.3$

⑭  $17 \times 0.03$

⑲  $0.3^2$

⑤  $0.5 \times 3$

⑩  $0.6 \times 0.02$

⑮  $28 \times 0.2$

⑳  $0.01^2$

Dividing decimals by a whole number.

a)  $8.76 \div 3$

$$\begin{array}{r} 2.92 \\ 3 \overline{)8.76} \end{array}$$

b)  $25.48 \div 7$

$$\begin{array}{r} 3.64 \\ 7 \overline{)25.48} \end{array}$$

## Part Two

Work out:

①  $23.6 \div 4$

⑥  $22.4 \div 4$

⑪ Share £4.65 equally between five people

②  $85.5 \div 5$

⑦  $2.36 \div 4$

③  $3.5 \div 7$

⑧  $8.55 \div 5$

④  $51 \div 3$

⑨  $0.35 \div 7$

⑤  $5.1 \div 3$

⑩  $2.24 \div 4$



On these pages you will use a calculator to work out a mixture of number problems.

## M

Copy the grid below.

Use a calculator to fill in the grid using the clues (IGNORE ANY DECIMAL POINTS).

1		2			3	
				4		
				5		6
	7		8			
9		10			11	
				12		

### Clues across

- ①  $2.5 + 3.1 \times 2.4$
- ④  $90 \div 3 - 5 \times 4$
- ⑤  $203 \times 3 - (16 - 8)$
- ⑦  $2.5 \times 1.67$
- ⑨  $131 \times (32.71 + 17.29)$
- ⑪  $(72.8 - 32.8) \times (1.67 + 0.33)$
- ⑫  $\frac{90 + 22.8}{2.4}$

### Clues down

- ①  $(200 \div 4) + (40 + 2)$
- ②  $4081 - (2 \times 40)$
- ③  $(167.2 + 232.8) \times 2$
- ④  $2.6 - 1.9 \times 0.5$
- ⑥  $(71 + 39) \times (36 - 19)$
- ⑦  $2.5 \times 1.7$
- ⑧  $(5 + 90) \times (11 - 3)$
- ⑨  $\frac{105.4}{1.7}$
- ⑩  $(2053 - 92) \div (21.2 + 15.8)$
- ⑪  $(1.96 - 0.46) \times 60 - 3$

**E**

Copy the grid below.

Use a calculator to fill in the grid using the clues (IGNORE ANY DECIMAL POINTS).

1		2		3		4
5	6		7		8	
9			10			
	11				12	13
14			15			
	16					

*Clues across*

- ①  $\sqrt{289} + 11^2$
- ③ 13% of 28
- ⑤ 78% of 36
- ⑧  $9^2 - \sqrt{1}$
- ⑨  $\frac{(914 - 44)}{(7.2 + 2.8)}$
- ⑩ 90% of 600
- ⑪  $\frac{3}{5}$  of 110
- ⑫  $\sqrt{6.25}$
- ⑭  $\sqrt{(181.6 - 70 + 9.4)}$
- ⑮  $(1063 + 1012) - (1.8 - 7.8)$
- ⑯ Change from £10 if you spend £3.94 (answer in pence only).

*Clues down*

- ①  $8^2 \times 27$
- ②  $9^2 \times (17 - 7)$
- ③ £1.28 - 89 pence (answer in pence only).
- ④  $\frac{5}{8}$  of 640
- ⑥  $(109.4 + 186.6)^2$
- ⑦  $\frac{17 \times 200}{40}$
- ⑧  $(7194 - 3180) \times (7 - 5)$
- ⑬ 20% of 2550
- ⑮  $3^2 + 17$

On these pages you will investigate T-shapes on different sized grids.

## M

### T-shapes

- 1 Draw a grid as shown (your teacher may wish to give you a photocopied grid).

A large 'T' can be drawn inside the number square so that all 5 numbers in the T are inside the square.

1	2	3	4	5	6	7	8
9	10	11	12	13	14	15	16
17	18	19	20	21	22	23	24
25	26	27	28	29	30	31	32
33	34	35	36	37	38	39	40
41	42	43	44	45	46	47	48
49	50	51	52	53	54	55	56
57	58	59	60	61	62	63	64

The T can be moved around but it must stay upright.

1	2	3	4	5	6	7	8
9	10	11	12	13	14	15	16
17	18	19	20	21	22	23	24
25	26	27	28	29	30	31	32
33	34	35	36	37	38	39	40
41	42	43	44	45	46	47	48
49	50	51	52	53	54	55	56
57	58	59	60	61	62	63	64

The 'T' number is the first number in the top row.

We shall call the shape below T17 because the T-number is 17.

	17	18	19	
		26		
		34		

- 2 What is the smallest possible T-number?
- 3 Work out the total of the numbers in T21.
- 4 Find a rule which connects the T-number with the total of all the numbers in a T-shape (call this the T-total).

*FOLLOW THESE STEPS:*

- a) Find the T-total for T1 (i.e. add up all the numbers in T1.)
- b) Find the T-total for T2.
- c) Find the T-total for T3 then T4 then T5.
- d) Write the answers in a table like below:

<i>T-number</i>		<i>T-total</i>
<i>n</i>	→	T
1	→	
2	→	
3	→	
4	→	
5	→	

- e) Is there a pattern for the T-total numbers? They should increase by the same number each time.
- f) There will be a two-stage rule which connects the T-number with the T-total as follows:

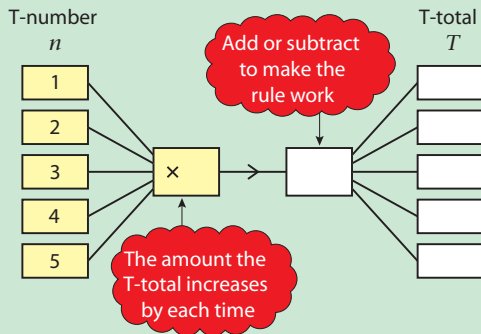

- g) Can you write your rule as a formula?

(Example. If rule is

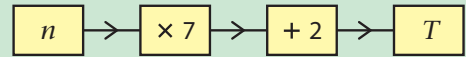

then  $T = 7n + 2$ )

- 5** It is *VERY IMPORTANT* to *CHECK* your rule. Look at the grid and find the T-total for T10. Use  $n = 10$  in your formula. Do you get the same answer?

Look at the grid and find the T-total for T30. Use  $n = 30$  in your formula. Do you get the same answer?

Hopefully everything works!

## E

- 1** Draw a grid as shown (called a  $7 \times 7$  grid) (your teacher may wish to give you a photocopied grid).

1	2	3	4	5	6	7
8	9	10	11	12	13	14
15	16	17	18	19	20	21
22	23	24	25	26	27	28
29	30	31	32	33	34	35
36	37	38	39	40	41	42
43	44	45	46	47	48	49

- 2** Find a rule which connects the T-number with the T-total for any T-shape drawn in this new grid (i.e. FOLLOW THE SAME STEPS AS YOU DID FOR THE  $8 \times 8$  GRID IN SECTION M).

**3**

1	2	3	4	5	6
7	8	9	10	11	12
13	14	15	16	17	18
19	20	21	22	23	24
25	26	27	28	29	30
31	32	33	34	35	36

Now do the same for a  $6 \times 6$  grid, i.e. find a rule which connects the T-number with the T-total for any T-shape drawn in this new grid.

- 4** Do the same as above for as many different grids as you can.

- 5 For each different grid, write down your formula or rule.

**Example**

$$4 \times 4 \text{ grid} \quad T = 8n + 11$$

$$5 \times 5 \text{ grid} \quad T = 8n + 21$$

$$6 \times 6 \text{ grid} \quad T = 8n + 31$$

$$7 \times 7 \text{ grid} \quad T = 8n + 41$$

$$8 \times 8 \text{ grid} \quad T = 8n + 51$$

Look at YOUR formulas. Can you see any more patterns.

*Write down* anything you notice.

Discuss with your teacher.

Write down anything else about doing this problem that you feel is useful.

On these pages you will add, subtract, multiply and divide negative numbers.

## M

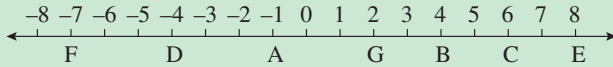

1 Put the following in order of size – smallest first:

- |                      |                       |
|----------------------|-----------------------|
| a) B, D, A, G        | f) 5, -2, 0, 4, 6     |
| b) A, D, F, B        | g) -12, 6, -9, 3, 18  |
| c) 4, -6, -2, 8      | h) 10, 2, -12, 4, -11 |
| d) 5, 10, -3, -9, 6  | i) -8, -1, 2, -3, -5  |
| e) -6, -12, 10, 4, 8 | j) -5, 4, -1, 3, 6    |

2 What letter above is the answer to:

- |             |             |            |             |
|-------------|-------------|------------|-------------|
| a) $-4 - 3$ | e) $2 - 6$  | i) $B - 5$ | m) $A - 6$  |
| b) $-4 + 3$ | f) $4 - 8$  | j) $E - 6$ | n) $G - 6$  |
| c) $4 - 5$  | g) $8 - 15$ | k) $D + 6$ | o) $C + 2$  |
| d) $-1 + 3$ | h) $-2 + 6$ | l) $G - 9$ | p) $D + 10$ |

3 Copy and complete the boxes below:

$$\begin{array}{l} -3 + 2 = -1 \\ -3 + 5 = \square \\ +4 - 2 = \square \\ \square - 3 = -8 \\ \square - 4 = -5 \end{array}$$

$$\begin{array}{l} +6 - 3 = \square \\ \square + 2 = -5 \\ -8 - 6 = \square \\ +4 - \square = -5 \\ -7 + \square = +2 \end{array}$$

$$\begin{array}{l} +12 - 6 = \square \\ \square - 3 = -2 \\ -8 + 2 = \square \\ -5 + \square = 0 \\ 0 + 6 = \square \end{array}$$

### Two signs together

Remember: it is possible to replace two signs next to each other by one sign as follows:

$$\begin{array}{l} + + = + \\ - - = + \\ - + = - \\ + - = - \end{array}$$

'same signs: +'

'different signs: -'

### Examples

a)  $5 - (-3) = 5 + 3 = 8$

b)  $-6 + (-2) = -6 - 2 = -8$

Work out:

- 4 a)  $5 - (+2)$                       e)  $-8 - (+2)$                       i)  $10 - (-5)$                       m)  $2 + (-3)$   
 b)  $5 - (-2)$                       f)  $-8 - (-2)$                       j)  $10 - (+5)$                       n)  $2 - (-3)$   
 c)  $-3 + (+4)$                       g)  $6 - (+3)$                       k)  $7 - (+8)$                       o)  $4 - (+6)$   
 d)  $-3 + (-4)$                       h)  $6 - (-3)$                       l)  $7 - (-8)$                       p)  $4 - (-6)$

5 Copy the following sequences and fill in the missing numbers:

- a)  $-5, -3, \square, \square, 3, 5$                       f)  $1.2, 0.8, \square, 0, \square$   
 b)  $-12, \square, -4, \square, 4, 8$                       g)  $-3.6, -2.7, \square, -0.9, \square$   
 c)  $-8, -5, \square, \square, 4, 7$                       h)  $-50, \square, 0, 25, \square$   
 d)  $-10, \square, -2, 2, 6, \square$                       i)  $\square, \square, -1, 5, 11$   
 e)  $-20, -12, \square, \square, 12, 20$                       j)  $\square, \square, 1, 10, 19$

### Multiplying and dividing

A	B		C	D	
↓	↓	In the sequence of multiplications	↓	↓	In this sequence
$5 \times 3 = 15$		shown, the numbers in column A	$-3 \times 3 = -9$		the numbers in
$5 \times 2 = 10$		go down by one each time.	$-3 \times 2 = -6$		column C go down
$5 \times 1 = 5$		The numbers in column B	$-3 \times 1 = -3$		by one each time.
$5 \times 0 = 5$		go down by five each time.	$-3 \times 0 = 0$		
$5 \times -1 = -5$		Continuing the sequence:	$-3 \times -1 = 3$		The numbers in
$5 \times -2 = -10$		We see that:	$-3 \times -2 = 6$		column D <i>increase</i>
$5 \times -3 = -15$			$-3 \times -3 = 9$		by 3 each time.
		We see that:			We see that:

When a positive number is multiplied by a negative number the answer is negative.

When two negative numbers are multiplied together the answer is positive.

For division, the rules are the same as for multiplication.

### Examples

$$-3 \times (-7) = 21$$

$$5 \times (-3) = -15$$

$$-12 \div 3 = -4$$

$$20 \div (-2) = -10$$

$$-40 \div (-20) = 2$$

$$-1 \times (-2) \times (-3) = -6$$

**E**

Work out:

- |                           |                     |                     |                      |
|---------------------------|---------------------|---------------------|----------------------|
| <b>1</b> a) $2 \times 5$  | b) $2 \times (-5)$  | c) $-2 \times 5$    | d) $-2 \times (-5)$  |
| <b>2</b> a) $3 \times 6$  | b) $3 \times (-6)$  | c) $-3 \times 6$    | d) $-3 \times (-6)$  |
| <b>3</b> a) $12 \times 4$ | b) $12 \times (-4)$ | c) $-12 \times 4$   | d) $-12 \times (-4)$ |
| <b>4</b> a) $8 \times 7$  | b) $8 \times (-7)$  | c) $-8 \times 7$    | d) $-8 \times (-7)$  |
| <b>5</b> a) $4 \times 9$  | b) $4 \times (-9)$  | c) $-4 \times 9$    | d) $-4 \times (-9)$  |
| <b>6</b> a) $10 \div 2$   | b) $10 \div (-2)$   | c) $-10 \div (-2)$  | d) $-10 \div 2$      |
| <b>7</b> a) $18 \div 3$   | b) $18 \div (-3)$   | c) $-18 \div (-3)$  | d) $-18 \div 3$      |
| <b>8</b> a) $42 \div 7$   | b) $42 \div (-7)$   | c) $-42 \div (-7)$  | d) $-42 \div 7$      |
| <b>9</b> a) $48 \div 12$  | b) $48 \div (-12)$  | c) $-48 \div (-12)$ | d) $-48 \div 12$     |
| <b>10</b> a) $77 \div 11$ | b) $77 \div (-11)$  | c) $-77 \div (-11)$ | d) $-77 \div 11$     |

**11** Find the missing numbers:

- |                             |                              |                             |
|-----------------------------|------------------------------|-----------------------------|
| a) $-4 \times \square = 12$ | e) $\square \times (-3) = 9$ | i) $-2 \times \square = 20$ |
| b) $3 \times \square = -12$ | f) $12 \div \square = -6$    | j) $-3 \times \square = 6$  |
| c) $-8 \div (-4) = \square$ | g) $\square \div (-3) = 2$   | k) $-2 \times \square = 4$  |
| d) $5 \times \square = -5$  | h) $\square \div 5 = -4$     | l) $(-1)^2 = \square$       |

On this page you will find and use factors, multiples and prime numbers.

## Remember:

*Multiples* are the numbers in a multiplication table.

8, 16, 24, 32, 40, . . . are multiples of 8.

A *factor* is a number which divides exactly into another number (there will be no remainder).

The factors of 10 are 1, 2, 5, 10.

A *prime* number can only be divided by two different numbers (these are the number 1 and itself).

The first three prime numbers are 2, 3 and 5.

## M

- 1 Write down the first 5 multiples of:  
 a) 2      b) 6      c) 4      d) 7      e) 9
- 2 a) Write down the first 6 multiples of both 3 and 5. What is the lowest number in both lists?  
 Do the same for      b) 5 and 6      c) 4 and 5
- 3 From these lists pick out the multiples of the number in the brackets:  
 a) 2   3   5   7   10   12   (3)  
 b) 4   6   8   10   11   15   (4)  
 c) 3   5   7   9   11   15   (5)  
 d) 2   4   6   8   10   12   (6)
- 4 Write down all the prime numbers shown in Question 3.

## E

- 1 Write down *all* the factors of the following numbers:  
 a) 12      c) 24      e) 20      g) 22  
 b) 18      d) 32      f) 30      h) 33
- 2 Write down the next prime number after:  
 a) 30      b) 37      c) 50      d) 24
- 3 Which of these numbers are multiples of 6:  
 a) 36      b) 64      c) 48      d) 666